

METAL DETECTOR

DENVER MET-100

Instruction Manual



“CAUTION: Before starting to use the metal detector please familiarize yourself with your country’s local laws and regulations on where you’re allowed to use the metal detector and for which findings you’re allowed to keep and for which findings you must turn in to the authorities. Also take most care not to use the metal detector in any area which might contain dangerous items such as explosives from a war or powercables or gaslines or

any other dangerous items.”

The Metal Detector is a versatile and easy-to-use metal detector. It has higher sensitivity and has the ability to differentiate the ferrous metals and nonferrous metals. It is suitable for beginners.

Please read the manual carefully before using the unit.

CONTENTS

Specification

Assembly

Batteries

Panel and Controller

Quick-Start

Field Operation

Caution

Trouble Shooting Guide

Specification:

- Operation Modes: One kind
No-motion Mode: As long as there is metal object around the search coil, the detector will have a response.
- Adjusting DISCRIMINATION
- Adjusting TUNE
- Adjusting VOLUME
- Low Battery Indication
- 6.5 inch Water Proof Search Coil
- 1/8 inch Earphone Jack (earphone not supplied)
- Batteries Six AA Batteries (not supplied)

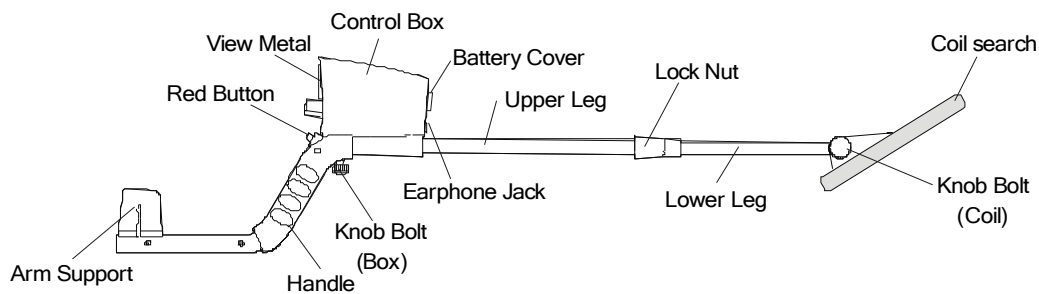

Assembly

Assembly is easy and requires no special tools.

1. Align the rounded plastic part raised on the handle, with the rounded lower groove at the control box bottom (Figure.1). Push the two parts tightly.

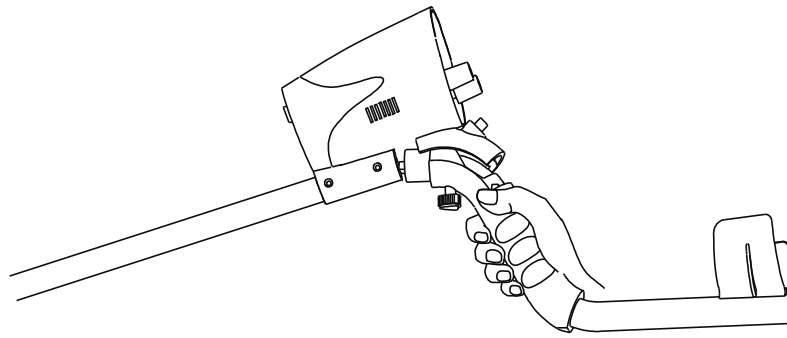

Figure.1

2. Align the threaded bolts at the handle bottom, with the knobs under the control box, lock it with the bolts (Figure.2).

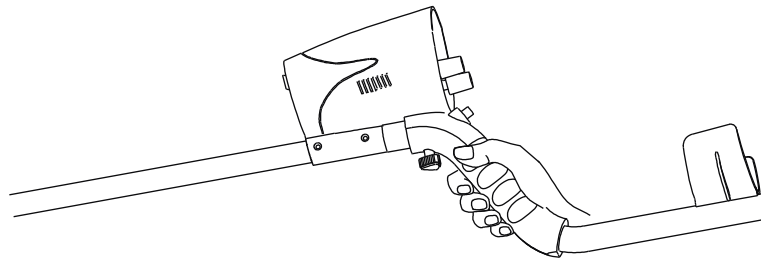

Figure.2

3. Turn the stem's lock nut clockwise until it loosens, lengthen or shorten the stem so when you stand upright with your detector in your hand, the search coil is level with and about 1/2 inch above the ground with your arm relaxed at your side. (Figure.3).

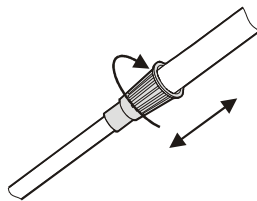

Figure.3

4. Loosen the knobs at the search coil's end, then adjust the search coil to the desired angle, let the search coil be parallel with the ground. Be careful not to mistake the location of the search coil (Figure.4).



Figure.4

Batteries

Please use six AA alkaline batteries.

1. Press the “key” on the battery compartment in the direction of the arrow, pull out the battery compartment cover (Figure.5). Note: the UP words is engraved on the battery compartment, don’t mistake the direction.

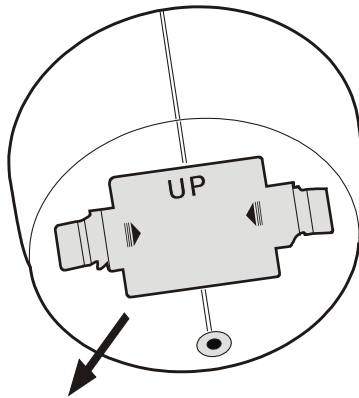

Figure.5

2. Insert six pcs AA batteries into the compartment as indicated by the polarity symbols marked inside the compartment (Figure.6).

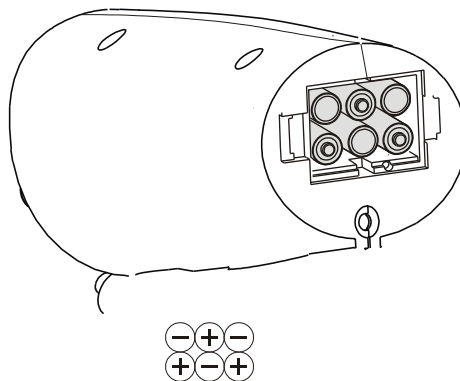

Figure.6

3. Close the battery compartment cover, please take care that the UP-side is up.
4. Six alkaline batteries may be used for more than 40 hours. If you do not plan to use the detector for a long time, remove the batteries.
5. Do not mix old and new batteries.

Panel and Controller

The Panel Controller (Figure.7)

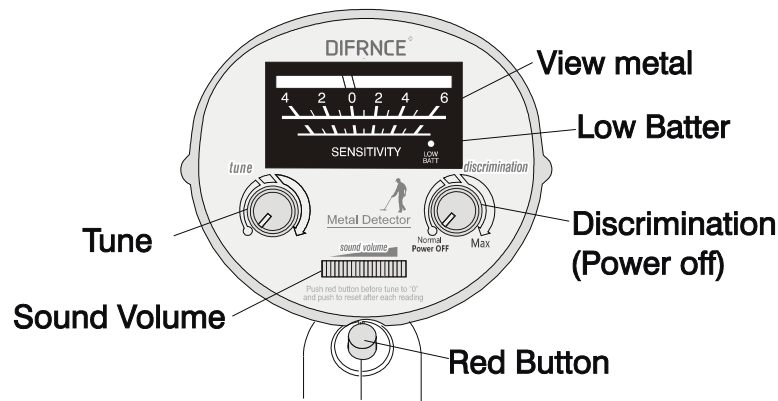

Figure.7

- Power off: Power on/off power supply. The same knob with the DISC. Turn DISCRIMINATION knob until red LED lights shortly up and then set to NORMAL
- TUNE: It is cooperated with the Red Tuning Button, and adjust balance to “0” (yellow part of display).
- Red Button: It is cooperated with TUNE to adjust balance. Keep holding red button down and at the same time rotate TUNE knob until dial in display is set at “0”(Yellow part of display)
- DISC: Adjust DISC will help the operator to differentiate the ferrous metals and nonferrous metals. Note: when it’s in the “NORMAL” position, the detector sensitivity is the most strong.
- Volume: Is used to adjust the loudness of the speaker.
- Low Battery Indication: When the red LED lights are on all the time then this indicates the batteries are low on power. Please change to new fresh batteries
- Earphone Jack: When an earphone (not included) is plugged in, the speaker will no longer sound.

Quick Start:

To get you master how to operate the metal detector quickly, we suggest that you should read the quick start carefully, and practice indoor. When you are familiar with the detector, you can hunt for the treasures just about anywhere.

1. Prepare with a sort of metal samples
 - an iron nail
 - a pull-tab and a nickel coin
 - a zinc coin
 - a silver coin
2. Lay the metal detector properly
 - In order to avoid the metals influence the detector, be sure to lay the the metal

detector properly.

- Lay the search coil properly, keep the angle between search coil and aluminum stem is about 140° . Please note not to mistake it (Figure.8)

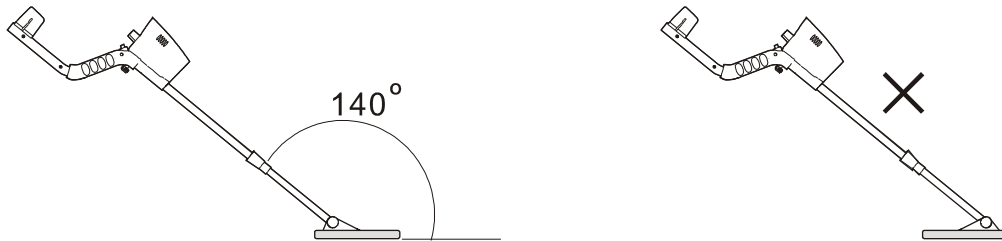

Figure.8

- Place the detector on a wooden or plastic table. Let the search coil exceeds the table edge about more than 5 inches (15cm). (Fig.9)

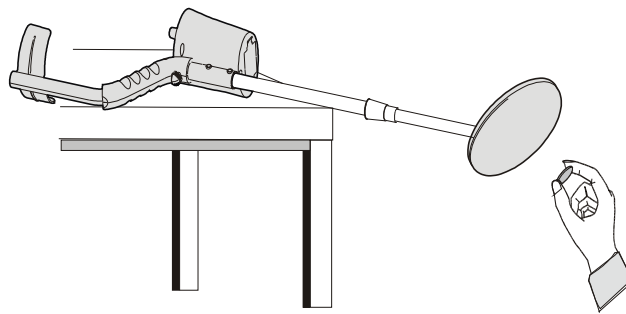

Figure.9

- Please take off the watch, ring or other metal objects on your hand or arm. Keep the detector away from the wall, floor and other metal objects.
 - Be sure to keep the detector away from the light, TV, computer and mobile telephone, which can cause electro-magnetic interference.
3. Turn on
Turn on the power supply. Turn DISC knob power on until red LED light shortly up and then set to NORMAL.
 4. Adjust balance.
Keep holding red button down and at the same time rotate TUNE knob until dial in display is set at "0" (Yellow part of display). Release the Red Button. The meter pointer should maintain near the "0", now the balance has been adjusted. The detector is in the sensitive detection state. (Fig.10).

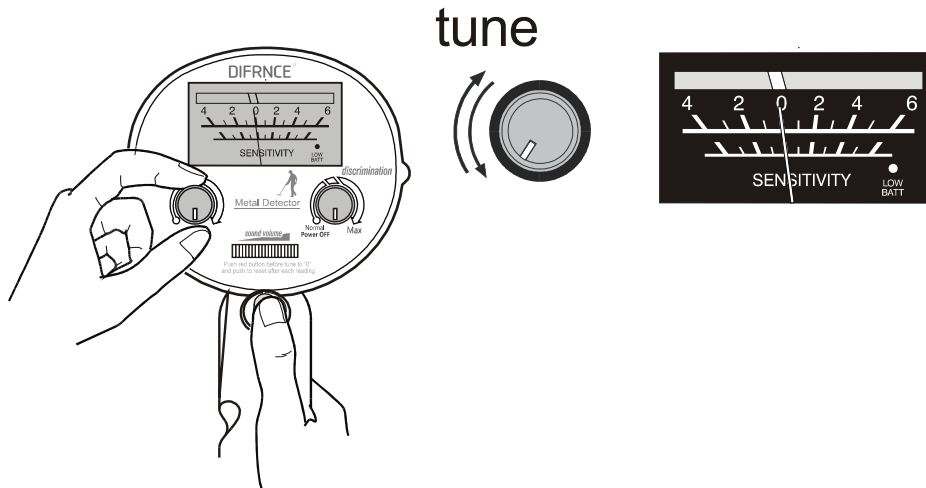

Figure.10

- Adjust the Volume potentiometer, let you can hear the light hum tone, don't adjust it too loud.
 - Once you adjust the “DISC” button, you should adjust the balance over again. In general, you should only press the Red Button to let the detector return to the balance state.
 - During operating, if there is no metals around detector, while the meter pointer deviates from the “0” position, you should also adjust the balance over again.
5. Test samples, discriminate ferrous metal and nonferrous metal.
- Set the “DISC” knob to “NORMAL”. Adjust the balance to let the meter pointer points “0”. Adjust “VOLUME” to let the detector sound a light hum tone.
 - Let the metal samples approach the search coil in turn, pay attention to the meter pointer swing and the voice change.
 - When the iron nail approach the search coil slowly, the meter pointer will deflect to the left, and the sound will turn light. When the iron nail is more closer to the search coil, the meter pointer will deflect to the left more and the sound turns more lighter, until it disappears. (Figure.11)

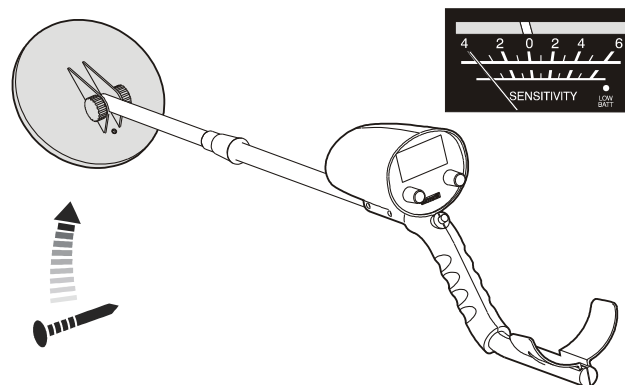

Figure.11

- Let other nonferrous metals approach the search coil, the meter pointer will deflect to the right, and the sound will turn louder. (Figure.12)

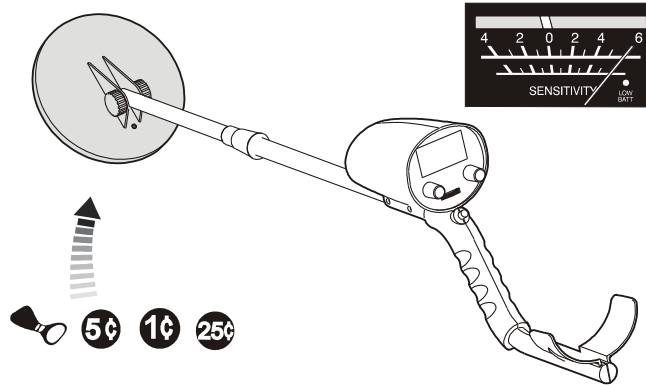

Figure.12

6. Discriminate silver

- Set the “DISC” knob to “MAX”. Adjust the balance to let the meter pointer points “0” and the detector sound a light hum tone.
- Let the silver coin approach the search coil slowly, the meter pointer will deflect to the right, and the sound will turn loud. (Figure.13)

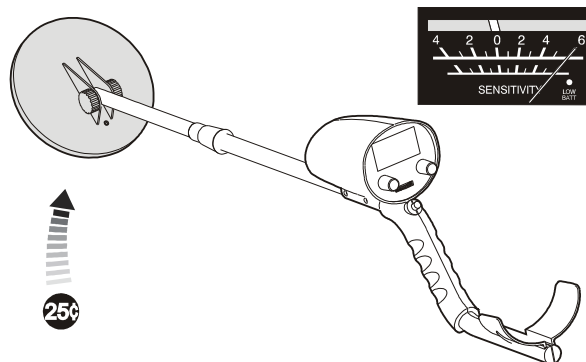

Figure.13

- Let other metal samples approach the search coil slowly, the meter pointer will deflect to the left, and the sound will turn light. (Figure.14)

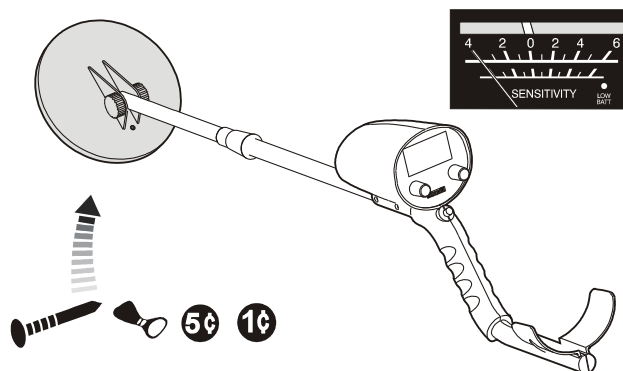

Figure.14

7. Discriminate different metals approximately

We take nickel coin and pull tab as an example to explain the approximate discrimination method.

- Set the DISCRIMINATION to about “12:00” position (Figure.15). Adjust the balance to let the detector sound a hum tone, and the show is “0”

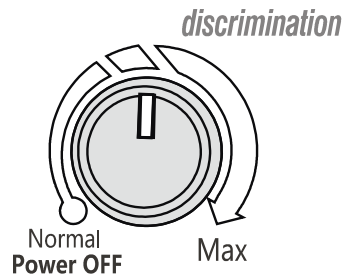

Figure.15

- Let the iron nail, nickel coin and pull tab approach the search coil slowly, the sound tones light, and the meter pointer deflects to the left.
 - Let the higher conductivity objects, such as zinc coin and silver coin approach the search coil slowly, the sound tones louder, and the meter pointer deflect to the right.
 - The “12:00” position is the nickel coin and pull tab discrimination position.
 - Rotate the “DISC” knob from “NORMAL” to “MAX”, you can find the different metals discrimination position. The metals with low conductivity, discrimination position is anear the left side, and the iron discrimination position is in the most left (NORMAL).The metals with high conductivity, discrimination position is anear the right side, and the silver discrimination position is in the most right (MAX).
8. Explanation
- Discriminating metals is based on the change of sound and meter pointer direction. The discrimination is preliminary, and it’s only a reference for treasure hunters.
 - When the DISC is in the “NORMAL” position, the detector sensitivity is the most.
9. Operation outdoors
- By learning, you have learned how to operate the detector. In the wild, as the soil, sea sand, ores and other environmental impacts and the interference of electromagnetic fields, the detector sensitivity and discrimination location will be changed. You should practice time after time and accumulate the experience to master the skill of detect gradually, and you will taste the joy of treasure-hunting.

Field Operation

Metal detector is used outdoors. There is too much metals indoors, and also all kinds

of electrical equipments that will bring interference signals, so it's not fit for using the detector.

Field detection is more complicated, the composition of the detected regional soil, the component, size, shape and the oxidation degree of the underground metals will all affect the detection results. This chapter is only the general steps of the field detection. The operator should practice time after time and accumulate experience to achieve good results.

1. Turn on

Turn DISC knob power on until red LED light shortly up and then set to "NORMAL". Set the VOLUME to the mid, the detector may sound a tone or may be silent.

2. Adjust balance

Keep holding red button down and at the same time rotate TUNE knob until dial in display is set at "0" (Yellow part of display). Release the Red Button, the meter pointer should maintain points to "0" position or near the "0" position. Adjust the "VOLUME", the detector sound a light hum tone, now the balance has been adjusted.

We remind the operator specially, once you adjust the "DISC" button, you should adjust the balance over again. When the detection environment has a change, you should also adjust the balance over again.

In general, after the balance being adjusted, and some balance deviation being occurred, you should only press the Red Button to let the detector return to the balance state.

3. Adjust volume

The detector is based on the direction of meter pointer deflection and change of sound to detect metals, and it's more sensitive to judge by the sound. After the balance being adjusted, adjusting the volume will get a light hum tone, don't adjust it too loud.

4. Adjust DISC

In general, set the "DISC" to "NORMAL", the sensitivity is the most at this time. If you find a ferrous metal, the detector tone will turn light, and the meter pointer swing to the left. If you find a nonferrous metal, the detector tone will turn louder, and the meter pointer swing to the right. You should further determine the general type of nonferrous metals by DISC.

Since the soil will deviate the discrimination position, we suggest you take some samples with you, such as iron nail, pull tab, nicker coin, silver coins. Bury these samples in the detection soil respectively, try detecting and observe the different metals discrimination position. It will help you judge the type of the target, in case you omit the treasures that you want to find.

5. Move the search coil

When moving the search coil, you should move it at a constant speed, not unsteadily. Let the search coil be parallel with and about 1/2 inch from the surface, not to swing it like a pendulum high and low above the ground.

(Figure.16,17)



Figure.16

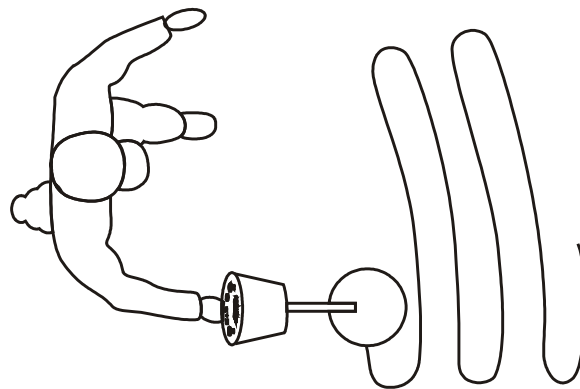

Figure.17

Move slowly in left to right motions close over ground until display dial shows reading. (Either to left/red side or to right/green side). Reading to left/red side, means smaller iron article, for example iron nail. Reading to right/green, means other metal (could be coin or gold ring) but can also be big iron article. You need to dig up to see what it is.

When finding metal objects, you should move the search coil on the ground according to figure 18, in order to determine the metal position exactly. The nearer the search coil from the object, the more strong the response is.

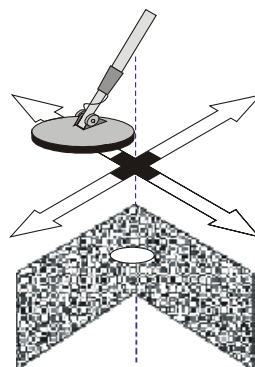

Figure.18

6. Using the earphone

To the change of sound, using the earphone is more sensitivity, and you will get

better detection result.

Caution

- 1) Before detection every time, you should press Red Button to adjust balance, let the detector be in most sensitive state. But when detecting, you should not press the Red Button.
- 2) The volume just be adjusted to let you could hear the sound, not adjust it too louder. At this time, the people is the most sensitive to the sound.
- 3) In areas with heavy traffic, please don't wear earphone, in case an accident occurs.
- 4) Always obtain permission before searching any site.
- 5) Keep away from the region that may bury electrical line, cable line or pipeline, in particular the pipes that are full of flammable gases and liquids.
- 6) Do no detect in the military area that may bury bombs or gas explosives.
- 7) When digging out the target, use the reasonable method; do not destroy the vegetation. Leave the land and vegetation as it was after excavation.
- 8) When using earphone, don't set it too louder, in case it'll destroy your hearing.

Trouble Shooting Guide

SYMPTOM	SOLUTION
No power	<ol style="list-style-type: none">1. Be sure that the polarity of batteries is installed correctly.2. Replace the batteries.
The unit is silent when turns on, and the meter pointer doesn't move, it seems there is no electricity.	The balance has a deviation. Press the Red Button, and adjust the TUNE knob to let the detector be in balance state.
Sound an irregular tone.	<ol style="list-style-type: none">1. Make sure there is no other metal detector operating around.2. Don't use it indoors, because there is many metals there.3. Make sure whether there is electromagnetic interference sources, such as power lines, cables, electronic fences and so on. Keep away from these areas.4. The ground is serious magnetized.

DENVER®

www.denver-electronics.com



Electric and electronic equipment contains materials, components and substances that can be hazardous to your health and the environment, if the waste material (discarded electric and electronic equipment) is not handled correctly.

Electric and electronic equipment is marked with the crossed out trash can symbol, seen below. This symbol signifies that electric and electronic equipment should not be disposed of with other household waste, but should be disposed of separately.

All cities have established collection points, where electric and electronic equipment can either be submitted free of charge at recycling stations and other collection sites, or be collected from the households. Additional information is available at the technical department of your city.

Imported by:

DENVER ELECTRONICS A/S

Omega 5A. Soefte

DK-8382 Hinnerup

Denmark

www.facebook.com/denverelectronics