

DENVER®

Bruksanvisning

Alarm Clock

CRL-330NR



www.facebook.com/denverelectronics

www.denver-electronics.com

Før du tar i bruk dette produktet, må du lese hele denne bruksanvisningen grundig.

Produktinformasjon

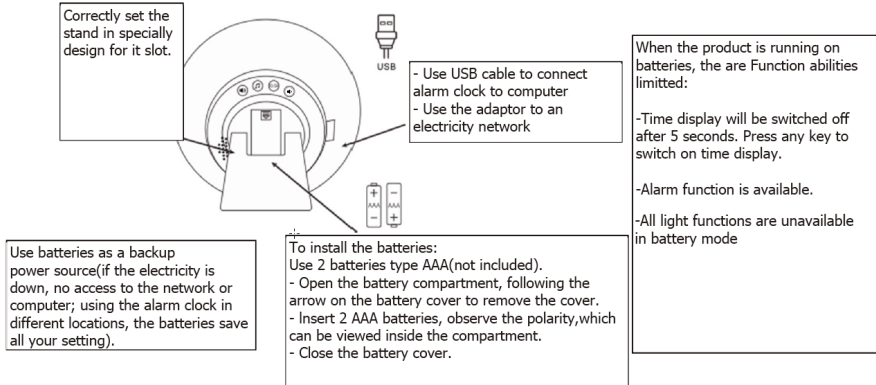

EN	NO
Correctly set the stand in specially design for it slot.	Sett stativet riktig i spesialdesign for sporet.
- Use USB cable to connect alarm clock to computer	- Bruk USB-kabel for å koble vekkerklokken til en datamaskin
- Use the adaptor to an electricity network	- Bruk adapteren til et strømnett
Use batteries as a backup power source (if the electricity is down, no access to the network or computer; using the alarm clock in different locations, the batteries save all your setting)	Bruk batterier som backup strømkilde (hvis strømmen er nede, ingen tilgang til nettverket eller datamaskinen, ved bruk av vekkerklokken på forskjellige steder, lagrer batteriene alle dine innstillinger)
To install the batteries:	Installere batterier:
Use 2 batteries type AAA (not included).	Bruk 2 batterier type AAA (ikke inkludert).

- Open the battery compartment, following the arrow on the battery cover to remove the cover.	- Åpne batterirommet, følg pilen på batteridekselet for å fjerne dekselet.
- Insert 2 AAA batteries, observe the polarity, which can be viewed inside the compartment.	- Sett inn 2 AAA batterier, observere polariteten, som kan sees inne i rommet.
- Close the battery cover.	- Lukke batteridekslet.
When the product is running on batteries, they are Function abilities limited:	Når produktet kjører på batterier, er funksjonene begrenset:
- Time display will be switched off after 5 seconds. Press any key to switch on time display.	- Tidsvisning vil bli slått av etter 5 sekunder. Trykk på en hvilken som helst tast for å slå på tidsvisning.
- Alarm function is available.	- Alarmfunksjon er tilgjengelig.
- All light functions are unavailable in battery mode	- Alle lysfunksjoner er utilgjengelige i batterimodus

Setting current time

When the power is connected, the hours indication starts to blink

Hours Setting:

Use \oplus \ominus to adjust hour

To confirm press \odot

Minute Setting:

Use \oplus \ominus to adjust minute

To confirm press \odot

If the indication is stopped touch \odot again.

12H-24H-format

Press $\odot/24$ key to switch the time format between 12H and 24H

12H
AM or PM will appear on time display.

**Changing current time**

Touch \odot button
The hours indication starts to blink.

Hours Setting:

Use \oplus \ominus to adjust hour

To confirm press \odot

Minute Setting:

Use \oplus \ominus to adjust minute.

To confirm press \odot

If the indication is stopped touch \odot again.

Intensity of time display

Press \odot key to select the display intensity



Low

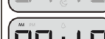



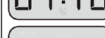













HIGH



OFF



EN	NO
Setting current time	Stille inn tiden
When the power is connected, the hours indication starts to blink	Når strømmen er tilkoblet, begynner timevisningen å blinke
Hours Setting:	Time Innstilling:
Use \oplus \ominus to adjust hour	Bruk \oplus \ominus til å justere time
To confirm press \odot	For å bekrefte trykk \odot
Minute Setting:	Minutt Innstilling:
Use \oplus \ominus to adjust minute	Bruk \oplus \ominus for å stille minutt
To confirm press \odot	For å bekrefte trykk \odot
If the indication is stopped touch \odot again.	Hvis indikasjonen er stoppet, trykk på \odot igjen.
12H-24H-format	12T-24T-format
Press $\odot/24$ key to switch the time format between 12H and 24H	Trykk på $\odot/24$ tasten for å bytte tidsformat mellom 12H og 24H
12H AM or PM will appear on time display.	12H AM eller PM vises på tidsvisning.
Changing current time	Endre nåværende tid



Touch  button	Trykk på  knappen
The hours indication starts to blink.	Timevisningen begynner å blinke.
Hours Setting:	Time Innstilling:
Use   to adjust hour	Bruk   til å justere time
To confirm press 	For å bekrefte trykk 
Minute Setting:	Minutt Innstilling:
Use   to adjust minute.	Bruk   til å justere minutt.
To confirm press 	For å bekrefte trykk 
If the indication is stopped touch  again.	Hvis indikasjonen er stoppet, trykk på  igjen.
<i>Intensity of time display</i>	<i>Intensitet av tidsvisning</i>
Press  key to select the display intensity	Trykk på  tasten for å velge skjermintensiteten
LOW	LAV
HIGH	HØY
OFF	AV

Lys-simulering av soloppgang

Når alarmtiden er innstilt, vil oppvåkingslyset slå seg på 30 minutter før alarmtiden i lav lysstyrke og gradvis øke lysstyrken. På alarmtiden vil lysstyrken være full. Den naturlige lyden spilles i 2 minutter på alarmtiden.

Under oppvåkning spiller alarmen



- Trykk på  knappen for å pause alarmen i 5 minutter. Etter 5 minutter vil alarmen spilles igjen i 2 minutter. Trykk på hvilken som helst knapp, unntatt  for å stoppe lyden.
- Trykk og hold  for å slå av oppvåkingslyset.



**Setting the alarm
wake-up time**
Touch  button to switch on/off alarm mode.
/  symbol appears/disappears on clock display.







Press and hold  button to set alarm.

The hours indication starts to blink.



⇒ Hours Setting:
Use   to adjust hour.
To confirm press

⇒ Minute Setting:
Use   to adjust minute.
To confirm press

If the indication is stopped touch  again.

Nature sounds
Press  key to select the alarm sound
Use   to select 1-6 sounds. Press  to confirm selection.

⇒ Each sound (1-6) will play 5 sec before you choose.

⇒ Press   Key to select volume level 00-15

EN	NO
Setting the alarm wake-up time	Stille inn alarmtiden
Touch  button to switch on/off alarm mode.	Trykk på  knappen for å slå på/av alarmmodus.
 /  symbol appears/disappears on clock display.	 /  symbolet vises/forsvinner på klokkevisning.
Press and hold  button to set alarm.	Trykk og hold nede  for å stille inn alarm.
The hours indication starts to blink.	Timevisningen begynner å blinke.

Hours Setting:	Time Innstilling:
Use \oplus/\ominus to adjust hour.	Bruk \oplus/\ominus til å justere timen.
To confirm press	For å bekrefte trykk
Minute Setting:	Minutt Innstilling:
Use \oplus/\ominus to adjust minute.	Bruk \oplus/\ominus til å justere minutt.
To confirm press	For å bekrefte trykk
If the indication is stopped touch \odot again.	Hvis indikasjonen er stoppet, trykk på \odot igjen.
Nature sounds	Natur lyder
Press \mathcal{R} key to select the alarm sound	Trykk på \mathcal{R} tasten for å velge alarmlyden
Use \oplus/\ominus to select 1-6 sounds. Press \mathcal{R} to confirm selection.	Bruk \oplus/\ominus til å velge 1-6 lyder. Trykk \mathcal{R} for å bekrefte valget.
Each sound (1-6) will play 5 sec before you choose.	Hver lyd (1-6) vil spille 5 sekunder før du velger.
Press \odot/\ominus Key to select volume level 00-15	Trykk på \odot/\ominus tasten for å velge volumnivå 00-15

Setting the Sunset time

Touch \odot to switch on/off sunset mode

\odot/\odot symbol appears/disappears on time display.

Press and hold \odot to set

The hours indication starts to set.

Hours Setting:

Use \oplus/\ominus to adjust hours. To confirm press \odot

minute setting:

Use \oplus/\ominus to adjust minute. To confirm press \odot













Light

Touch \odot to switch on the light

Use \oplus/\ominus to adjust the level (1-10) of the brightness
Second touch of \odot will switch on automatic color changing mode

Use \oplus/\ominus to select color: Green, Red, Blue, Purple, Orange, Indigo

Third touch \odot to switch off the light

EN	NO
Setting the Sunset time	Innstilling av tidspunktet for solnedgang
Touch  to switch on/off sunset mode  /  symbol appears/disappears on time display.	Trykk  for å slå på/av solnedgangsmodus  /  symbolet vises/forsvinner på tidsvisning.
Press and hold  to set	Trykk og hold  for å stille inn
The hours indication starts to set.	Timevisningen begynner å stilles inn.
Hours Setting:	Time Innstilling:
Use   to adjust hours. To confirm press 	Bruk   til å justere timer. For å bekrefte trykk 
minute setting:	minutt innstilling:
Use   to adjust minute. To confirm press 	Bruk   til å justere minutt. For å bekrefte trykk 
Light	Lys
Touch  to switch on the light	Trykk på  for å slå på lyset
Use   to adjust the level (1-10) of the brightness	Bruk   til å justere nivået (1-10) på lysstyrken
Second touch of  will switch on automatic color changing mode	Andre trykk på  vil slå på automatisk fargeskiftemodus
Use   to select color: Green, Red, Blue, Purple, Orange, Indigo	Bruk   til å velge farge: Grønn, rød, blå, lilla, oransje, indigo
Third touch  to switch off the light	Tredje trykk på  slår av lyset

Lys-simulering av solnedgang

 30 min før solnedgangstid, er lyset er slått på med 100 % lysstyrke og deretter reduseres lysstyrken gradvis og vil slå av ved solnedgangstidspunktet.

Under solnedgang er lyset slått på, og du kan: Trykke og holde  for å slå av lyset.

Beskrivelse

- * Led tidsvisning i 12T-24T-format
- * Lys-simulering for oppvåkning av soloppgang
- * Lys-simulering av solnedgang
- * 6 Natur lyder å våkne opp til
- * Nattbordlampe
- * Hvit lysstrøm: 73LM
- * 10 nivåer for lysstyrken
- * 6 farget lys + hvitt lys
- * Automatisk endring av fargelys
- * 15 volumnivåer
- * Berøringsmodus
- * Strømforsyning: DC 5V; 2xAAA batterier; USB kabel.

Merk: Når batteriet er lavt, kan det hende at produktet ikke fungerer riktig.
Bytt ut batteriet med et nytt batteri.



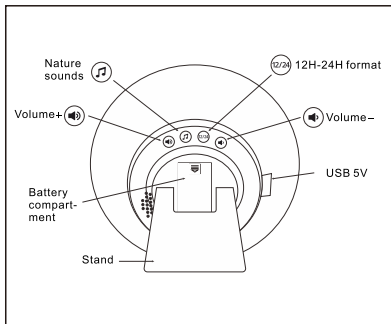
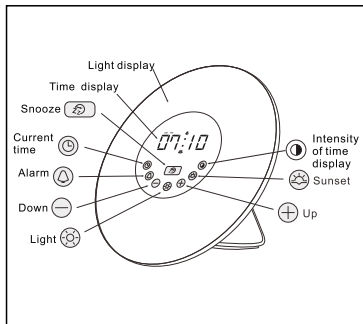

EN	NO
Light display	Lys display
Time display	Tidsvisning
Snooze	Slumre
Current time	Nåværende tid
Alarm	Alarm
Down	Ned
Light	Lys
Sunset	Solnedgang
Up	Opp
Nature sounds	Natur lyder
Volume -/+	Volum -/+
Battery compartment	Batterirom
Stand	Stativ
12H-24H format	12H-24H format
Intensity of time display	Intensitet av tidsvisning
USB 5V	USB 5V



Advarsel

- * Ikke trykk på to eller flere taster samtidig
- * For å unngå feilintervall på hver berøring må hver berøring vare i mer enn 1 sekund.
- * Hvis det oppstår feil, trekk ut støpselet i 3 sekunder.
- * Hvis batteriene ikke brukes i lang tid, må du fjerne batteriet.
- * Når batterispenningen er lav, vil produktet bli startet på nytt og alle innstillinger går tapt. Bytt batteriene.
- * Adapteren er kun beregnet for bruk med dette produktet. Ikke bruk adapteren for å lade andre enheter som f.eks. mobiltelefon.



Advarsel

MED ENERETT, OPPHAVSRETT DENVER ELECTRONICS A/S

DENVER®

www.denver-electronics.com



Elektrisk og elektronisk utstyr inneholder materialer, komponenter og stoffer som kan være farlig for din helse og for miljøet, hvis materialet (kassert elektrisk og elektronisk utstyr) ikke håndteres riktig.

Elektrisk og elektronisk utstyr er merket med en søppelbøtte med kryss over, som vist ovenfor. Dette symbolet betyr at elektrisk og elektronisk utstyr ikke skal kastes sammen med husholdningsavfall, men håndteres separat.

Alle byer har opprettet innsamlingspunkter, hvor elektrisk og elektronisk utstyr kan enten leveres inn gratis på resirkuleringsstasjoner og innsamlingspunkter, eller samles inn fra husholdninger. Mer informasjon er tilgjengelig hos lokale tekniske avdelinger.

Importert av:

DENVER ELECTRONICS A/S

Omega 5A, Soeften

DK-8382 Hinnerup

www.facebook.com/denverelectronics